



# PURGE/PRESSURIZATION SYSTEM

## SERIES 3000/MODEL 3004

### DATA SHEETS



Class I ( $\leq 250 \text{ ft}^3$ ) and Zone 2 ( $\leq 7.08 \text{ m}^3$ )

Description

Model 3004 is a Rapid Exchange® purging system that operates on a supply of compressed instrument air or inert gas. It regulates and monitors pressure within sealed protected enclosure(s), in order to remove and prevent flammable gas or vapor accumulations. The Model 3004 consists of three major components: (1) a pneumatic manifold assembly, (2) a differential enclosure pressure indicator and (3) a stainless steel face plate with mounting flange, or a Lexan® system start up instruction nameplate. Model 3003 is offered in three distinct variations, identified as "VM" (Vertical Mount), "HM" (Horizontal Mount), both available in WPS & WPSA styles, and "CK" (Component Kit) mounting configurations. The VM configuration features a filter regulator and face plate with a flange for mounting to a vertical surface. The HM configuration features a regulator and face plate with a flange for mounting on a horizontal surface. Finally, the CK configuration is a kit of parts including the pneumatic manifold assembly, the enclosure pressure indicator and a start-up instruction nameplate. The VM and HM configurations are intended for flange or frame mounting to a solid surface on or near the protected enclosure(s), while the CK configuration is intended for frame mounting through cutouts in a panel on or near the enclosure(s). With the addition of a Model GCK gauge conversion kit, all configurations can be mounted through the surface of a protected enclosure. The CK configuration provides a seal that withstands type 4 hosedown testing. Model 3004 accomplishes the required volume exchanges and maintains a safe pressure. Pepperl+Fuchs Model EPV-3 enclosure protection vent is required for proper operation. This process reduces the hazardous (classified) area rating within protected enclosure(s), in accordance with the NEC - NFPA 70, NFPA 496, ISA 12.4 and IEC 600 79-15 EN 50021.

Operation

In accordance with system instructions, start-up requires air supply to be engaged and enclosure power to be deenergized. The enclosure protection vent must be tested and enclosure(s) must be sealed. After transferring the valve key, locked into the pneumatic manifold's Rapid Exchange control valve stem, the enclosure pressure control valve is used to set a safe reading on the enclosure pressure indicator. When safe pressure is stable, the valve key is transferred and locked into the Rapid Exchange control valve stem and the Rapid Exchange control valve is then fully engaged. Upon completion of the Rapid Exchange cycle, (five minutes minimum) the Rapid Exchange control valve is disengaged to return to a safe enclosure pressure. Power can then be energized to the protected enclosure(s). Loss of safe pressure requires immediate attention, unless power to the protected enclosure(s) is deenergized. WPS and WPSA style systems include an explosion proof differential pressure switch with form "C" contacts for audible or visual alarm systems.

Rapid Exchange® is a Registered Trademark of Pepperl+Fuchs, Inc.

Lexan® is a registered trademark of the General Electric Company

Model 3004



Model 3004-LPS-CI-YZ-VML  
Vertical Mount Configuration



Model 3004-WPS-CI-YZ-HMT  
Horizontal Mount Configuration



Model 3004-LPS-CI-YZ-CK  
Component Kit Configuration



Standard Model Applications

Model Number:	3004	Model Number:	3004
Designation:	Type Y System RapidExchange® Purging	Designation:	Type Z and Ex [nP] System Rapid Exchange® Purging
Enclosure Volume:	250 ft <sup>3</sup> (7.08 m <sup>3</sup> ) max.	Enclosure Volume:	250 ft <sup>3</sup> (7.08 m <sup>3</sup> ) max.
<b>LPS Style</b>		<b>LPS Style</b>	
UL & FM Certified:	Cl. I, Div. 1, Group A-D	UL & FM Certified:	Cl. I, Div. 2, Group A-D
Rating Reduction:	Div. 1 to Div. 2	ATEX 'nP' Certified:	Zone 2, Group IIC
<b>WPS Style</b>		<b>WPS Style</b>	
UL & FM Certified:	Cl. I, Div. 1, Group C-D	Rating Reduction:	Div. 2 to Nonhazardous Zone 2 to Nonhazardous
Rating Reduction:	Div. 1 to Div. 2	<b>WPSA Style</b>	
<b>WPSA Style</b>		UL & FM Certified:	Cl. I, Div. 2, Group C-D
UL & FM Certified:	Cl. I, Div. 1, Group A-D	Rating Reduction:	Div.2to Nonhazardous
Rating Reduction:	Div. 1 to Div. 2	<b>WPSA Style</b>	
		UL & FM Certified:	Cl. I, Div. 2, Group A-D
		ATEX 'nP' Certified:	Zone 2, Group IIB+H <sub>2</sub>
		Rating Reduction:	Div.2to Nonhazardous Zone 2 to Nonhazardous
<b>Ex II 3G EEx [nP] II</b>			

## Model 3004 VM Configuration - The Vertical Mount System

### LPS (Less Pressure Switch)

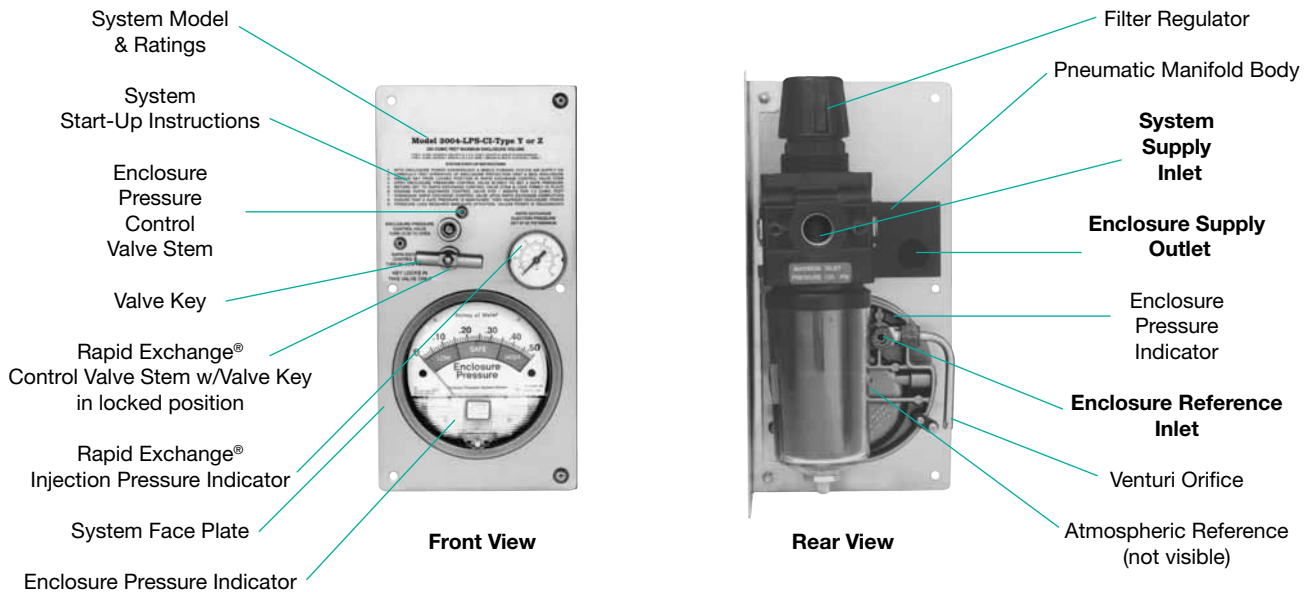

### Important Notes

- 1) The VM configuration is supplied with a mounting flange for right angle-attachment to a vertical surface external to the protected enclosure.
- 2) The VM configuration can also be frame mounted external to the protected enclosure through a 5" (127 mm) W x 10.75" (273 mm) H cutout in a suitable mounting surface.
- 3) Model GCK gauge conversion kit is required to panel mount the VM configuration through a 5" (127 mm) W x 10.75" (273 mm) H cutout in the protected enclosure surface.
- 4) See page 60 for Model GCK kit description and conversion procedure.

### WPS / WPSA (With Pressure Switch)

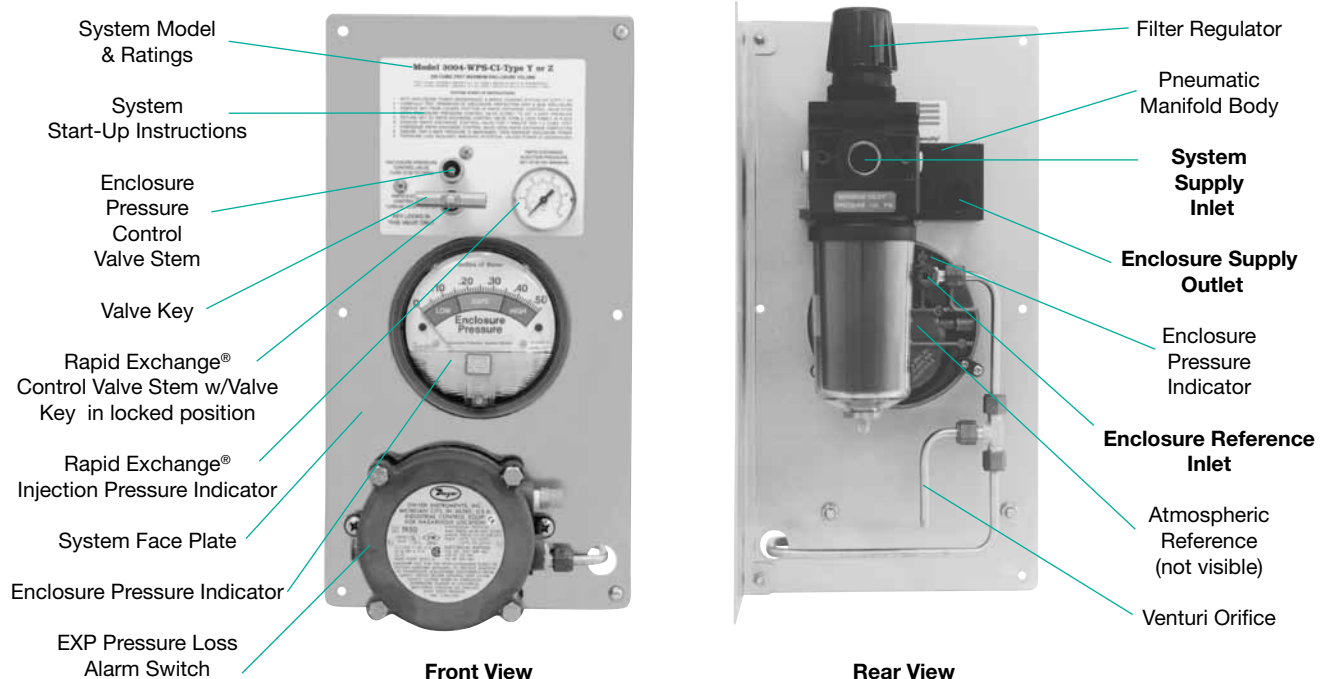

CONNECTION POINTS SHOWN ABOVE IN BOLD TEXT ON SYSTEM DIAGRAM

Model 3004 HM Configuration - The Horizontal Mount System

LPS (Less Pressure Switch)

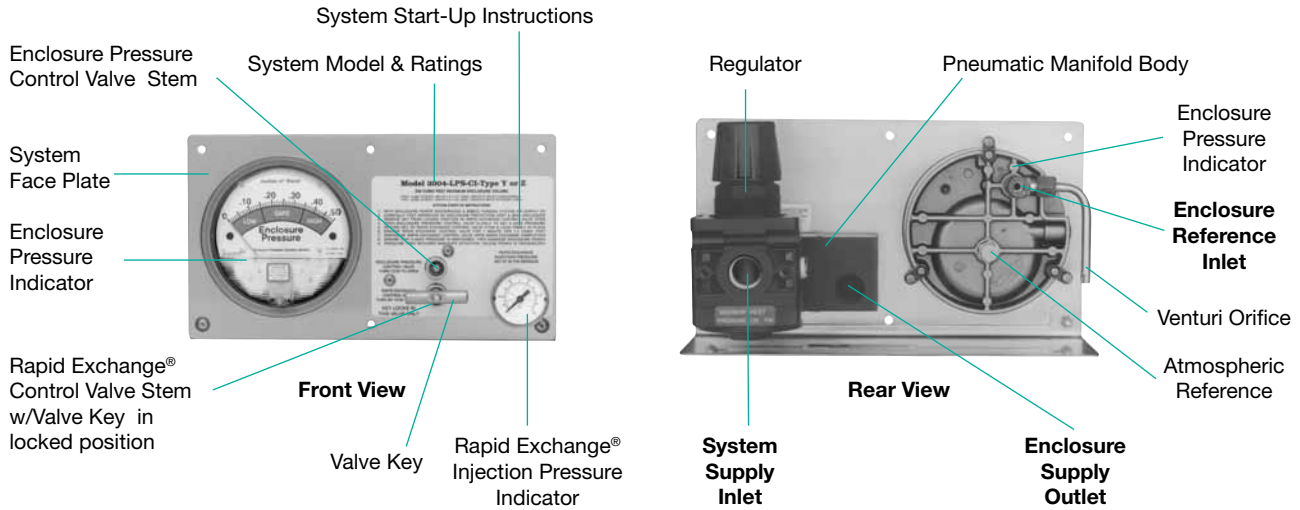

Important Notes

- 1) The HM configuration is supplied with a mounting flange for right-angled attachment to a horizontal surface external to the protected enclosure.
- 2) The HM configuration can also be frame mounted external to the protected enclosure through a 10.25" (260 mm) W x 5.5" (140 mm) H cutout in a suitable mounting surface.
- 3) Model GCK gauge conversion kit is required to panel mount the HM configuration through a 10.25" (260 mm) W x 5.5" (140 mm) H cutout in the protected enclosure surface.
- 4) See page 60 for Model GCK kit description and conversion procedure.

WPS / WPSA (With Pressure Switch)

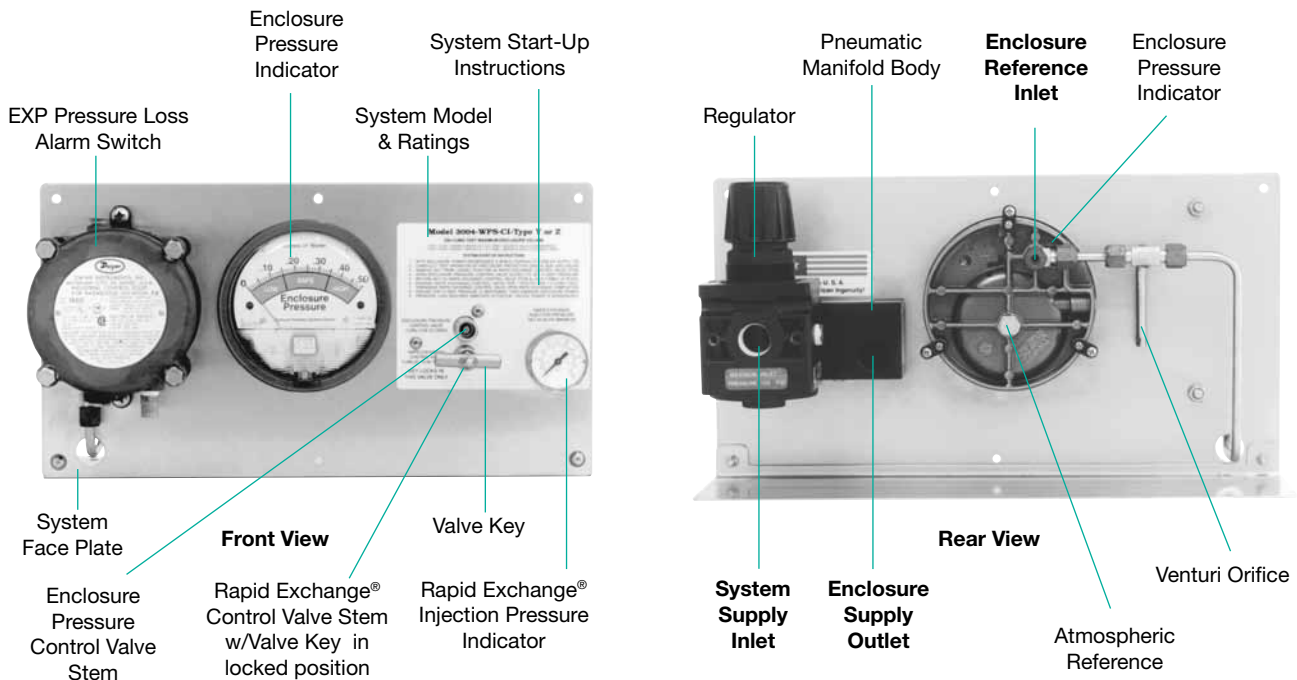

CONNECTION POINTS SHOWN ABOVE IN BOLD TEXT ON SYSTEM DIAGRAM

3000 SERIES

Type Y, Z & Ex [nP]

Model 3004 CK Configuration - The Component Kit System

**Part #1**  
Enclosure Pressure Indicator



Front View

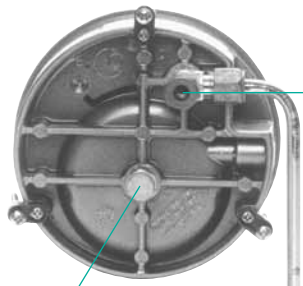

Rear View

Atmospheric Reference

Venturi Orifice

**Part #2**  
Pneumatic Manifold Assembly

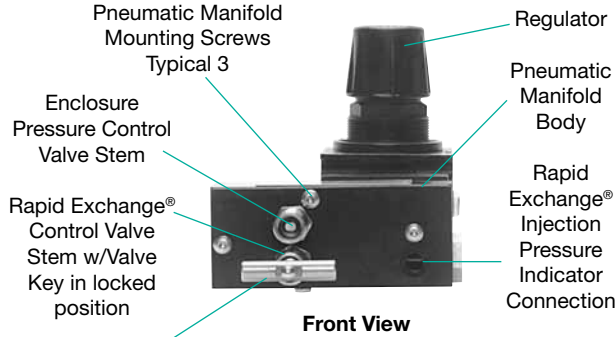

Front View

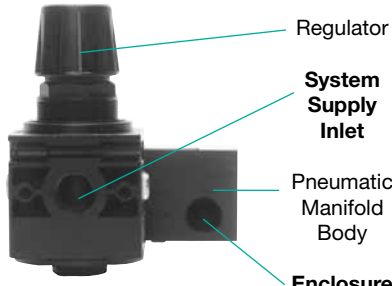

Rear View

**Part #3**  
Rapid Exchange® Injection Pressure Indicator



Front View



Side View

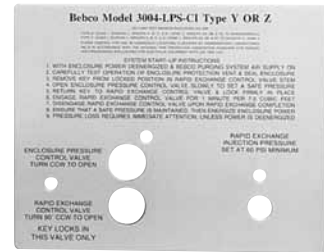

**Part #4**  
Start Up Instruction Nameplate

CONNECTION POINTS SHOWN ABOVE IN BOLD TEXT ON SYSTEM DIAGRAM

Important Notes

- 1) The CK Configuration is four discrete parts suitable for mounting through a set of cutouts in a vertical surface external to the protected enclosure.
- 2) A Model GCK gauge conversion kit is required to panel mount the CK configuration through a set of cutouts in the protected enclosure surface.
- 3) See page 60 for Model GCK kit description and conversion procedure.

CK Configuration System & Optional Remote Cube Filter Dimensions in Inches (mm)

**Pneumatic Manifold**

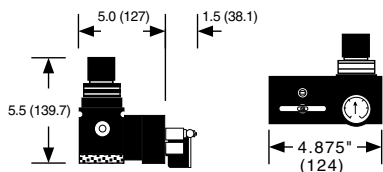

Side View

Front View

Model 3004 CK System Panel Cutout Pattern

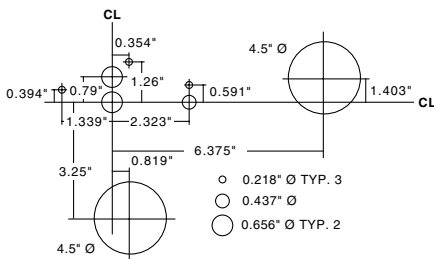

**Enclosure Pressure Gauge**

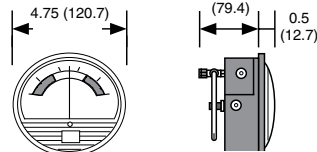

Panel Cutout 4.5 (114.3) Ø

Front View

Side View

**Side View Model RCF-8**

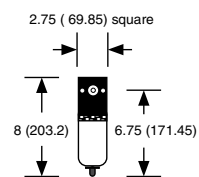

Model RCF-8 Panel Cutout Pattern

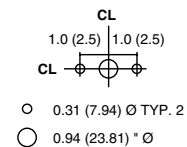

Helpful Hint

Note: Two optional Enclosure Pressure Gauge positions are shown on the Model 3004 CK System Panel Cutout Pattern to the left. The optional positions center gauge to the right or bottom side of System Nameplate.

Cut only one 4.5" (114.3 mm) Ø hole in panel.

**Model 3004 WPS VM Configuration & Flange Dimensions in Inches (mm)**

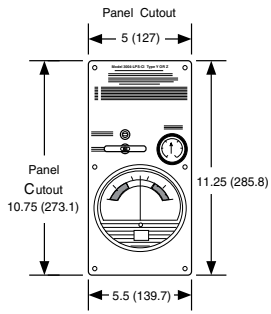

**VM Configuration Front View**

**LPS (Less Pressure Switch)**

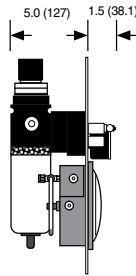

**VM Configuration Side View**

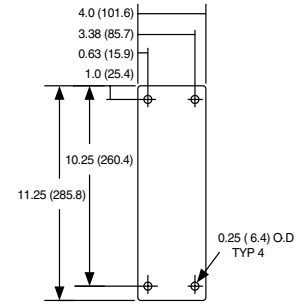

**Vertical Mount Flange Front View**

3000 SERIES

Type Y, Z & Ex [nP]

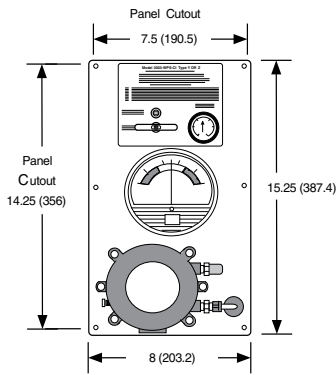

**WPS/WPSA VM Configuration Front View**

**WPS/WPSA (With Pressure Switch)**

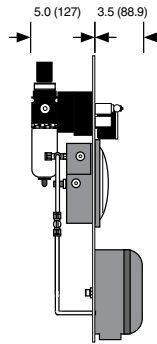

**WPS/WPSA VM Configuration Side View**

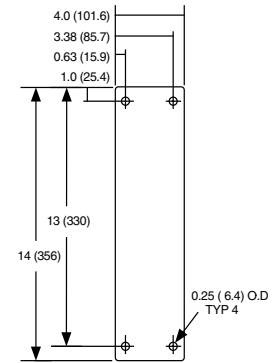

**WPS/WPSA Vertical Mount Flange Front View**

**Model 3004 HM Configuration & Flange Dimensions in Inches (mm)**

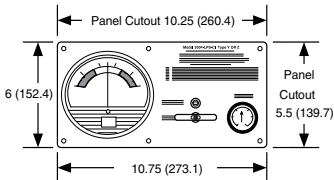

**LPS HM Configuration Front View**

**LPS (Less Pressure Switch)**

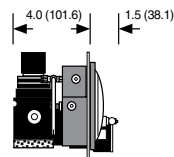

**LPS HM Configuration Side View**

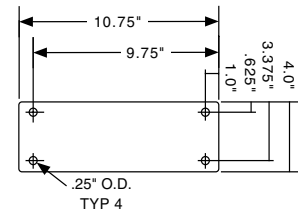

**LPS Horizontal Mount Flange Front View**

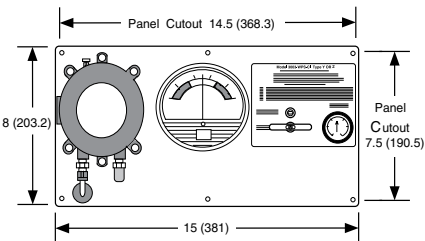

**WPS/WPSA HM Configuration Front View**

**WPS/WPSA (With Pressure Switch)**

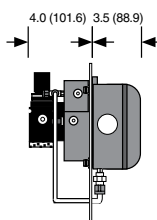

**WPS/WPSA HM Configuration Side View**

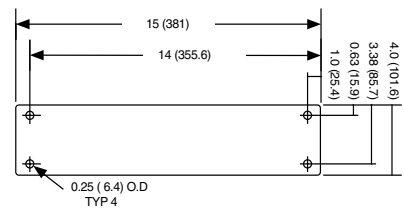

**WPS/WPSA Horizontal Mount Flange Front View**

Typical Model 3004 System Installation Details

External to the Protected Enclosure

Flange Mount HM Configuration with Model SMK-1 Fastener Kit

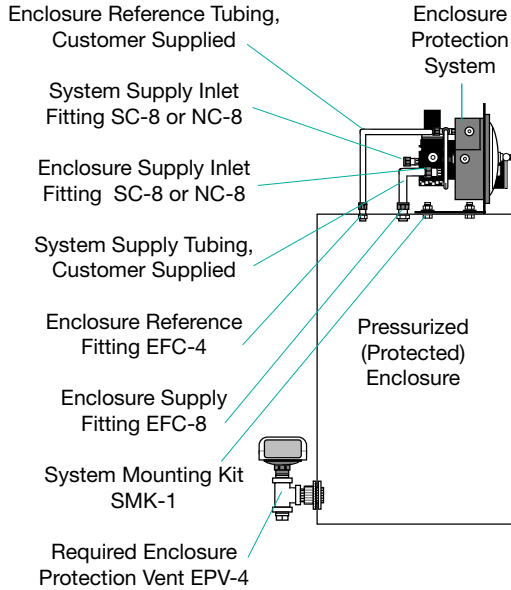

Internal to the Protected Enclosure

Panel Mount CK Configuration with Model RCF-8 Remote Cube Filter & Model GCK Gauge Conversion Kit

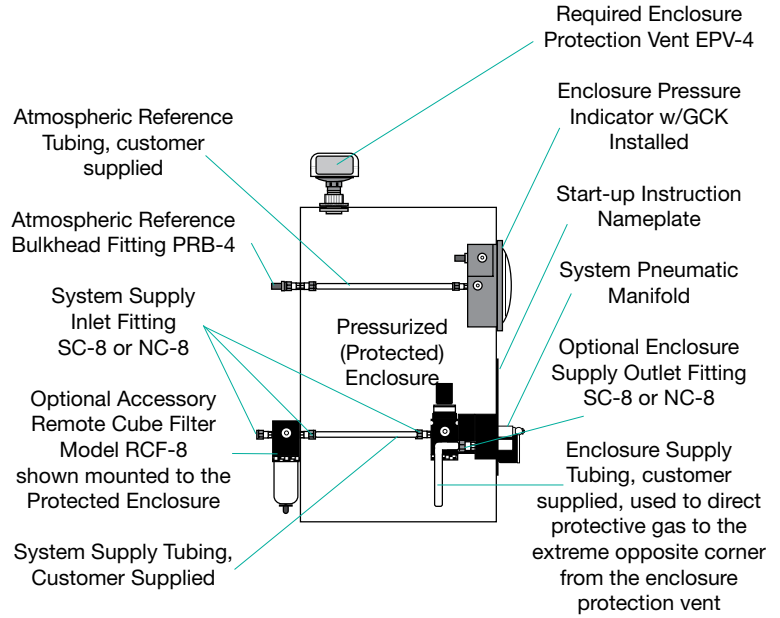

3000 SERIES

Type Y, Z & Ex [nP]

Standard and Panel Mount Pneumatic Installation Diagram

Standard Pneumatic Installation Diagram

See panel mounting conversion procedure on page 60

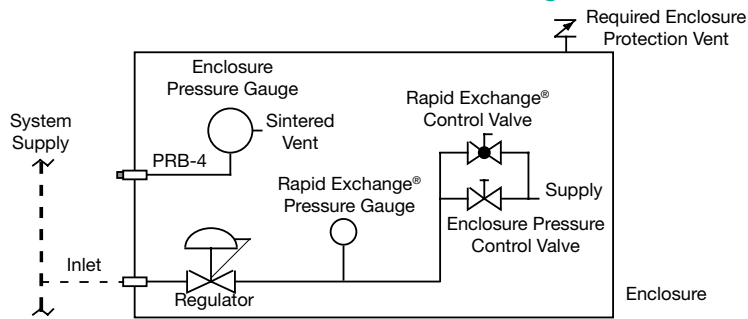

Panel Mount Installation Diagram

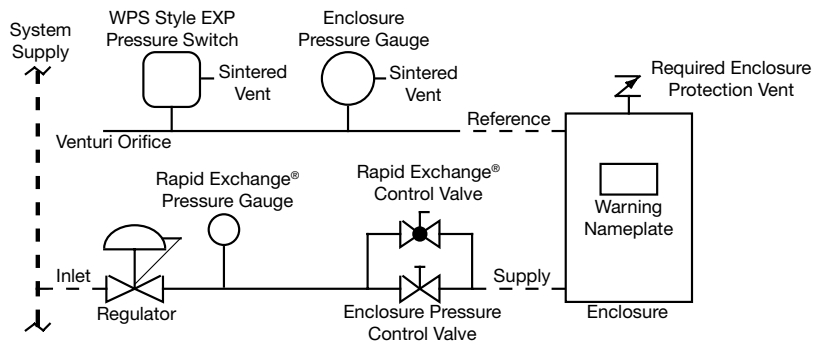

**VM Configuration Mounting Options**



**Model 3004-LPS-CI-YZ-VML**  
Flange Mounted to  
Flat Vertical Surface with  
Model SMK-1 Fastener Kit



**Model 3004-LPS-CI-YZ-VML**  
Flange Mounted to  
Vertical 2" Pipe Stand with  
Model PMK-1 Fastener Kit



**Model 3004-LPS-CI-YZ-VM**  
Frame or Panel\* Mounted  
Through Cutout in Suitable Surface  
with Model SMK-6m Fastener Kit

**HM Configuration Mounting Options**

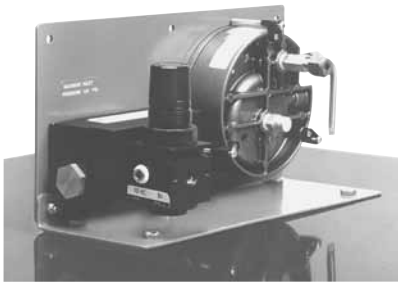

**Model 3004-LPS-CI-YZ-HMT**  
Flange Mounted to  
Flat Horizontal Surface with  
Model SMK-1 Fastener Kit

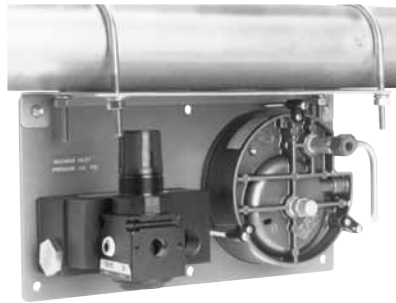

**Model 3004-LPS-CI-YZ-HMB**  
Flange Mounted to  
Horizontal 2" Pipe Stand with  
Model PMK-1 Fastener Kit

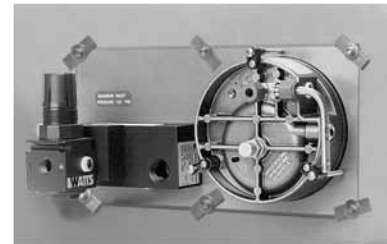

**Model 3004-LPS-CI-YZ-HM**  
Frame or Panel\* Mounted  
Through Cutout in Suitable Surface  
with Model SMK-6m Fastener Kit

**CK Configuration Mounting Options**



Front View



Rear View

**Model 3004-LPS-CI-YZ-CK**  
Rear View of Frame or Panel\* Mount  
Through Cutout in Suitable Surface with supplied fasteners

\* PANEL MOUNTED SYSTEMS REQUIRE A PEPPERL+FUCHS MODEL GCK FOR PROPER OPERATION - SEE PAGE 60

3000  
SERIES

Type Y, Z & Ex [nP]

## Model 3004 Panel Mount Conversion

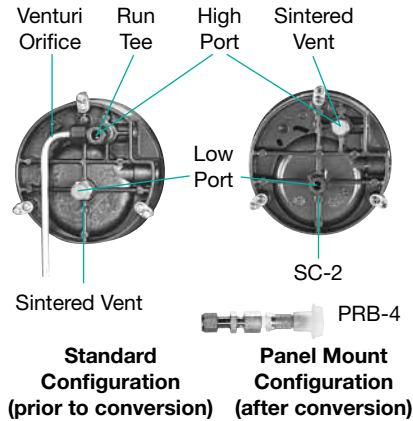

1. Secure one Model GCK Conversion Kit, kit includes a PRB-4 & SC-2 Fitting & Enclosure Pressure Gauge gasket.
2. Remove venturi orifice and run tee from the high port of the gauge and discard.
3. Remove sintered vent from low port.
4. Reinstall sintered vent into high port.
5. Install Model SC-2 fitting into low port.
6. Install Gauge gasket between gauge & mounting surface.
7. Install Model PRB-4 fitting through enclosure surface (vent end out) and connect tubing (customer supplied) between SC-2 & PRB-4.

## System Specifications

System Dimensions:	See page 6
Shipping Weight:	LPS-12 lb (5.4 kg) WPS-17 lb (7.7 kg)
Temp. Range:	-20 °F to +120 °F (-29 °C to +49 °C)
Supply Pressure Range:	80 - 120 psi (5.5 - 8.3 bar)
Capacity & Filtration:	8.5 oz @ 40 Micron
Supply Requirements:	clean air or inert gas
Safe Press. Setpoint:	0.25" (6.35 mm)
Safe Press. Flow Rate:	* 0.1 - 3.5 SCFH (2.8 - 99 l/hr)
Exchange Pressure:	* 3" - 5" (76.2mm - 127 mm)
Exchange Flow Rate:	** 30 SCFM /1800 SCFH (850 l/m / 50976 l/hr)
Exchange Time:	
4 Volume Exchange Rate:	1 min / 7.5 ft <sup>3</sup> (212.4 l/m)
5 Volume Exchange Rate:	1 min / 6.0 ft <sup>3</sup> (169.9 l/m)
System Supply Port:	1/2" FPT
Enclosure Supply Port:	1/2" FPT
Enclosure Reference Fitting:	1/4" Tube
Switch Setting (WPS & WPSA Only):	0.15" ± 0.02" (3.81 mm ± 0.51 mm)
Switch Conduit Port Size:	1/2" FPT
Switch Contact Ratings:	
WPS Style:	120 VAC @ 15 A
WPSA Style:	*** 120/220 VAC, 24 VDC @ 10 A; 125 VDC @ 50 mA
Switch (WPSA) Power Requirement:	24 / 120 / 240 VDC @ 3 / 4 / 11 watts

\* Enclosure integrity determines actual flow rate  
 \*\* With regulator set to 60 psi min. during exchange  
 \*\*\* Supply voltages 24 VDC and 240 VAC available upon request.

## Material Specifications

Regulator Body:	Zinc w/Enamel Finish
Regulator Handle & Bowl*:	Polycarbonate
Enclosure Pressure Gauge:	Alum. w / Enamel Finish
Rapid Exchange® Gauge:	Poly & Nickel Plated
Tube Fitting:	316 SS Forged Body
Tubing:	316 SS 1/4" .035 Welded
Fastener Hardware:	Alum. & Stainless Steel
System Face Plate:	316 14 Ga #3 Brush SS
System Mounting Flange:	316 SS Tumble Finish
Manifold Body:	Anodized Aluminum
Manifold Valves:	316 Stainless Steel
Mfr. ID Nameplate:	Silkscreen Lexan®
Enclosure Warning Nameplate:	Silk screened SS
EXP Pressure Switch Body:	Anodized Cast Aluminum

\* Refers to filter bowl supplied with VM mounting configuration.

## Model Number Designations

<b>3004 - LPS - CI - YZ - VM - ##</b>	
<b>Series Model Number</b>	3004
<b>System Style</b>	LPS - less pressure switch †WPS - with pressure switch WPSA - with pressure switch
<b>Area Classification</b>	CI - Class I Area
<b>System Type</b>	YZ - Div. 1 to Div. 2 Div. 2 / Zone 2 to Nonhazardous
<b>Mounting Configuration</b>	VML - vertical mount left left of enclosure VMR - vertical mount right right of enclosure HMT - horizontal mount top top of enclosure HMB - horizontal mount bottom bottom of enclosure CK - Component Kit - LPS style only
## - See Accessories Page 131 for additional factory installed accessories	
† Does not have ATEX certification	

## Model 3004 System Accessories (See accessories page for complete details)

<b>CONNECTION FITTINGS</b>	
NC-8	1/2" T x 1/2" P Ninety Connector
SC-8	1/2" T x 1/2" P Straight Connector
EFC-4	1/4" Flush Connector
EBC-4	1/4" Bulkhead Connector
EFC-8	1/2" Flush Connector
EBC-8	1/2" Bulkhead Connector
EPC-14	1 1/2" Pipe Connector

<b>ADDITIONAL ITEMS</b>	
SMK-1	System Mounting Kit - Flange
SMK-6m	System Mounting Kit - Frame/Panel

PMK-1	Pipe Mounting Kit
GCK	Gauge Conversion Kit
ILF-8	1/2" In-Line Filter Kit
RCF-8	1/2" Remote Cube Filter
EPSK-1	Explosion Proof Switch Kit (GRP C, D)
EPSK-1A	Explosion Proof Switch Kit (GRP A-D)
GPSK-1	General-purpose Switch Kit
RAH	Remote Alarm Horn
RAB-1	Div. 1 Remote Alarm Beacon
RAB-2	Div. 2 Remote Alarm Beacon

<b>ENCLOSURE PROTECTION VENTS</b>	
<b>ONE VENT REQUIRED WITH EACH SYSTEM</b>	
EPV-4-SA-00	Straight w/Spark Arrestor
EPV-4-SA-90	Rt Angle w/Spark Arrestor
<b>WARNING NAMEPLATES</b>	
EWN-1	Class I Enclosure Warning
ETW	Enclosure Temperature Warning
<b>INSTALLATION &amp; OPERATION MANUAL</b>	
129-0216	Inst. & Operation Manual

ONE (1) ENCLOSURE WARNING NAMEPLATE & ONE (1) INSTALLATION & OPERATION MANUAL ARE PROVIDED WITH EACH SYSTEM

Pepperl+Fuchs supplies purge/pressurization systems custom built to your specifications. To ensure the integrity of your system, certain accessory items must be factory installed.

The Model Number and Accessories Guide identifies those parts that must be included on your purge/pressurization system order.

### 3000 Series – Model Number Designations and Accessories Guide

3000 SERIES

Type Y, Z & Ex [nP]

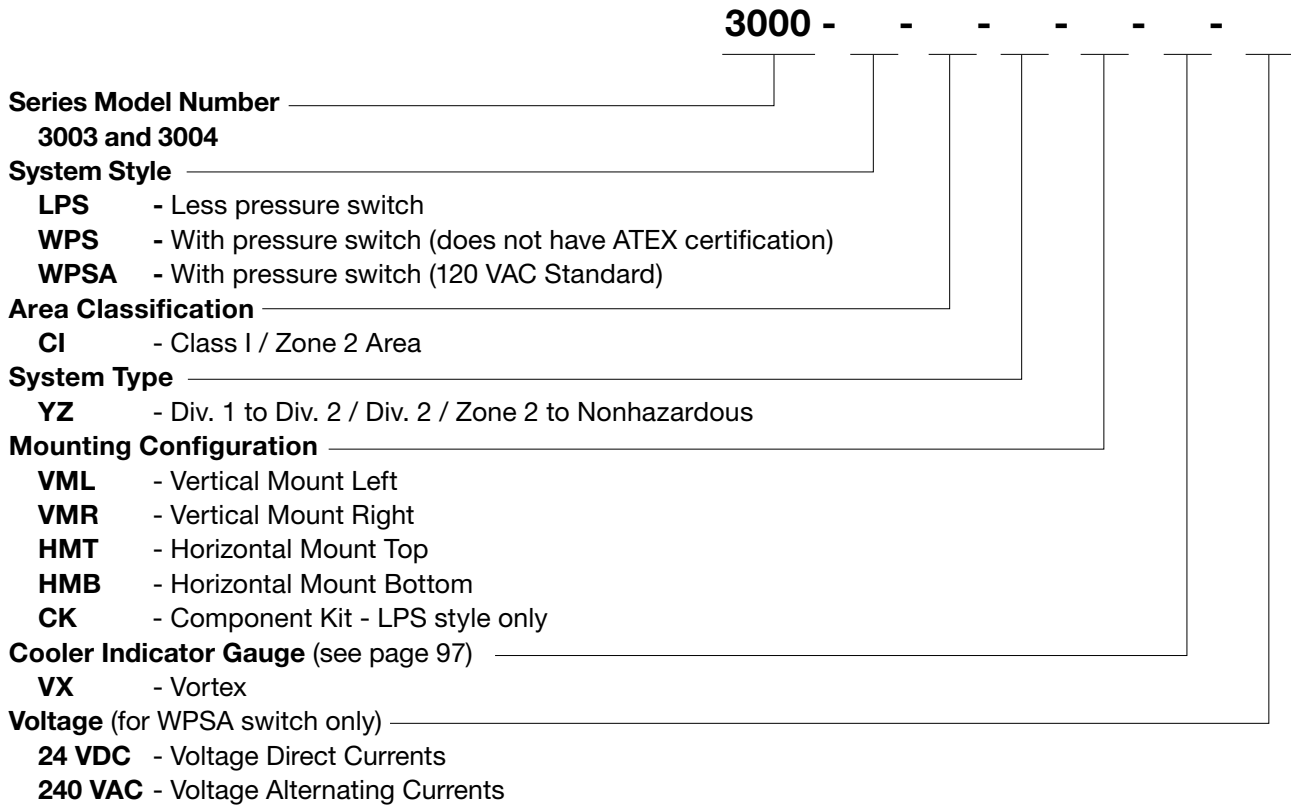

Description

The cooler indicator gauge, sometimes called the Vortex indicator gauge, is used on systems where there is cooling required after purging. Normally after the purging cycle, there is a small flow of protective gas required to compensate for leakages, and to keep a constant pressure within the enclosure so that the ingress of hazardous atmosphere cannot get inside the enclosure. This is known as pressurization. If the equipment inside the pressurized enclosure requires cooling, either a higher flow rate of protective gas is required through the pressurization valve, or a second source of cooling gas is introduced into the enclosure. The standard differential pressure gauge will indicate pressurization only up to 0.5 inches (13 mm) water, which may not be enough for cooling indication. The cooler indicator gauge is installed onto the pressurization/purge panel, and allows monitoring of the system during normal operation of the purge/pressurization system.

Cooler Indicator Gauge



Cooler Indicator Gauge  
(Vortex Indicator Gauge)

3000  
SERIES

Type Y, Z & Ex [nP]

Special Note

TO ORDER PURGE/PRESSURIZATION UNITS EQUIPPED WITH A COOLER INDICATION GAUGE, SPECIFY 'VX' IN THE MODEL NUMBER DESIGNATION.

Specifications

OPERATING RANGE

Full range:	0 to 5 " (0 to 127 mm) water
Low range red:	0 to 0.5 " (0 to 13 mm) water
Safe range green:	0.5 to 1.5 " (13 to 38 mm) water
Cooler/Rapid exchange range yellow:	1.5 to 4.5 " (38 to 114 mm) water
High range red:	4.5 to 5 " (114 to 127 mm) water

BODY COMPONENTS

Cover:	acrylic
Housing:	die cast aluminum coated to withstand 168 hour salt spray corrosion test

TECHNICAL DATA

Maximum overload pressure:	15 psig
Accuracy:	± 2% of full scale
Weight:	1.2 lb (510 g)
Process connection:	1/8" Female NPT duplicate high and low pressure taps, one pair side, one pair back



For over a half century, Pepperl+Fuchs has provided new concepts for the world of process automation. Our company sets standards in quality and innovative technology. We develop, produce and distribute electronic interface modules, Human-Machine Interfaces and hazardous location protection equipment on a global scale, meeting the most demanding needs of industry. Resulting from our world-wide presence and our high flexibility in production and customer service, we are able to offer complete individual solutions – wherever and whenever you need us. We are the recognized experts in our technologies – Pepperl+Fuchs has earned a strong reputation by supplying the world’s largest process industry companies with the broadest line of proven components for a diverse range of applications.

